

6" pipe float
part # 444062

SHELL WT: 16 LB.S
FOAM : 7.5 LB.S

SHIP WT: 23.5 LB.S

FLOATATION MAX: 192 LB.S

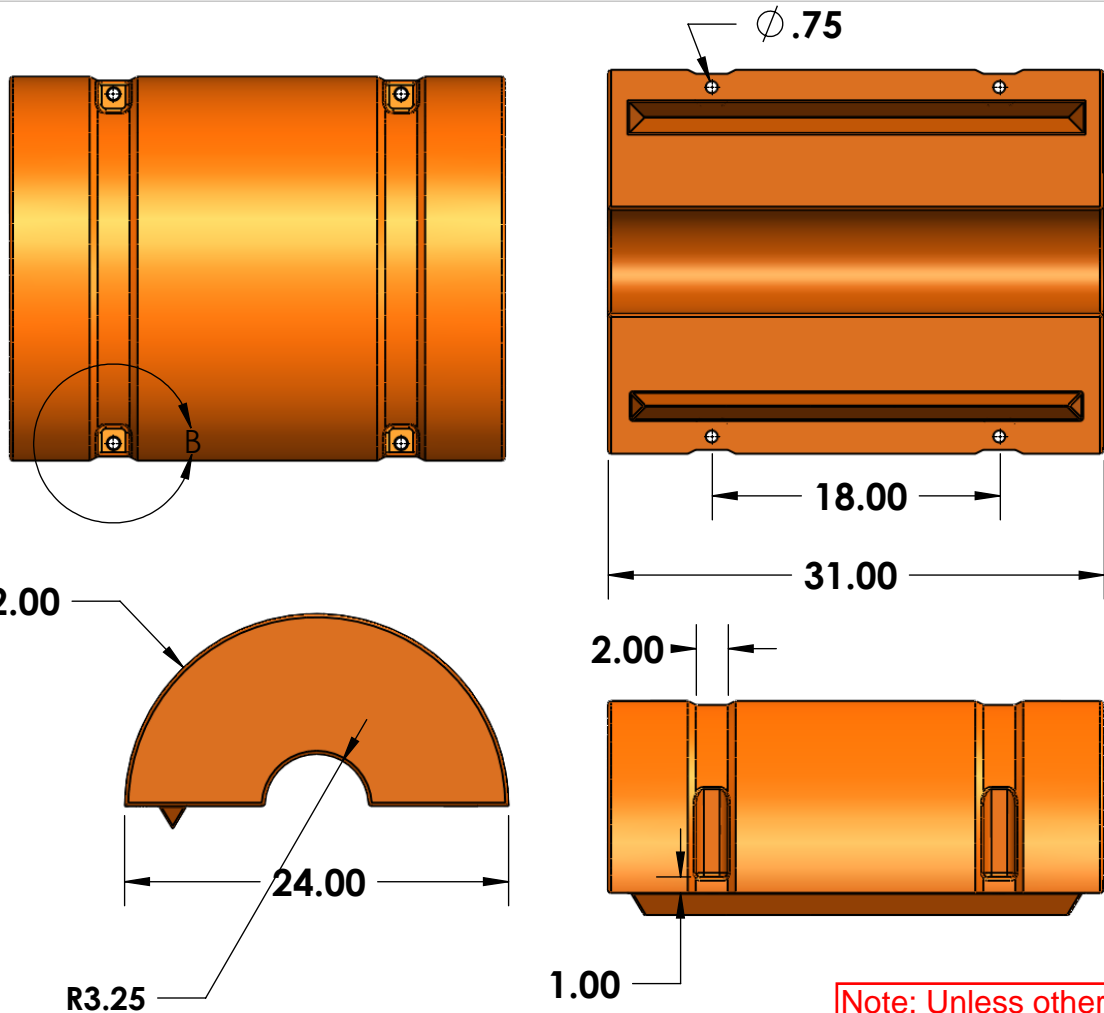

Note: Unless otherwise noted on this or other documents typical tolerances are +/- 0.05" per inch of linear length.

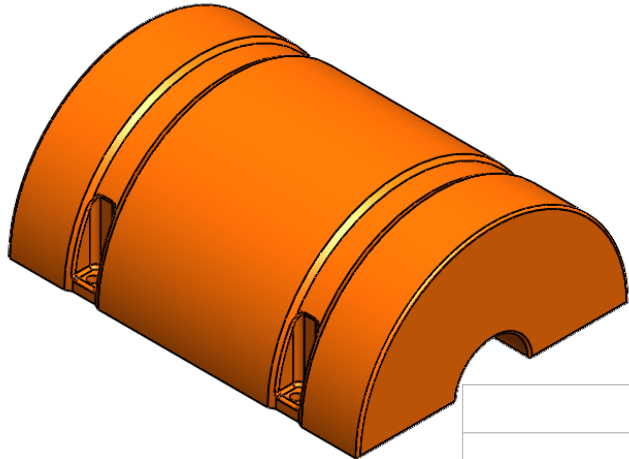

PROPRIETARY AND CONFIDENTIAL
THE INFORMATION CONTAINED IN THIS DRAWING IS THE SOLE PROPERTY OF ROTONICS MFG. INC.. ANY REPRODUCTION IN PART OR AS A WHOLE WITHOUT THE WRITTEN PERMISSION OF ROTONICS MFG. INC. IS PROHIBITED.

| | | | | |
|-------------|---------|--------------------------------------|-----------|------|
| | | UNLESS OTHERWISE SPECIFIED: | NAME | DATE |
| | | DIMENSIONS ARE IN INCHES | DRAWN | |
| | | TOLERANCES: | CHECKED | |
| | | FRACTIONAL ± | ENG APPR. | |
| | | ANGULAR: MACH ± BEND ± | MFG APPR. | |
| | | TWO PLACE DECIMAL ± | Q.A. | |
| | | THREE PLACE DECIMAL ± | COMMENTS: | |
| | | INTERPRET GEOMETRIC TOLERANCING PER: | | |
| | | MATERIAL | | |
| | | FINISH | | |
| NEXT ASSY | USED ON | | | |
| APPLICATION | | DO NOT SCALE DRAWING | | |

| | | |
|--|----------|--------------|
| TITLE: | | |
| 6" pipe float w bolts Part # 444062 | | |
| SIZE | DWG. NO. | REV |
| A | KG4091 | |
| SCALE: 1:12 | | SHEET 1 OF 1 |